

Key Electrical Characteristics		
Parameter / Symbol	Value / Description	Unit
$BV_{DSS \text{ min.}}$	650	V
$R_{DS(ON) \text{ Typ. @10V}}$	151	mΩ
$I_D$	20.4	A
$V_{TH \text{ Typ.}}$	3.0	V
$C_{iss \text{ Typ.}}$	1754	pF
$Q_g \text{ 10V}$	40.2	nC
ESD (HBM)	$\geq 2$	KV



## General Description

These devices are N-channel power MOSFET developed using Super Junction structure technology. There is high speed switching capacity, low  $R_{DS(ON)}$  parameter, excellent quality and characteristics for these devices. Moreover, it is a good choose in improved efficiency of circuit and raise power density are required. These features combine to be an advantage design for use in wide variety of application including switch mode power design.

## Features

- ✧ Fast Switching
- ✧ Low  $R_{DS(on)}$  resistance
- ✧ Low Switching Loss
- ✧ Improve ESD protection capabilities
- ✧ Stable thermal characteristics
- ✧ Excellent single pulse avalanche energy
- ✧ Pb-free Lead plating and RoHS compliant

## Potential Applications

- ◆ AC to DC converter
- ◆ LED lighting power module
- ◆ Consumption electronics adaptor or charger
- ◆ Network equipment and display power supply unit
- ◆ Switch Mode Power Supply

## Symbol and Pin assignment

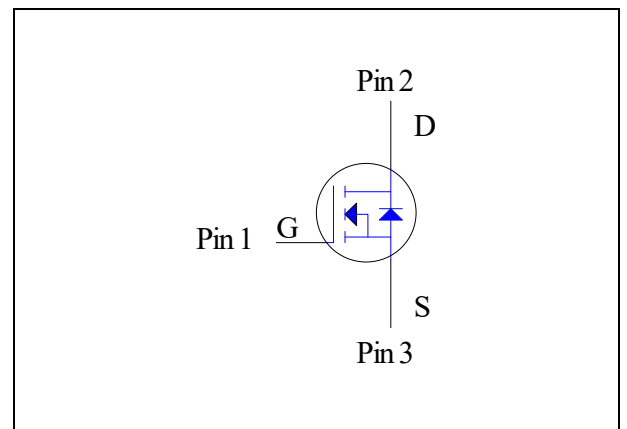

## Ordering Information

N.o	Item	Description
01	Orderable P/N	SJ650N180P2
02	Part Number	SJ650N180P2
03	Package Type	TO-220AB
04	Package Code	P
05	Packing Type	Tube
06	Quantity/pcs	50
07	RoHS Status	Halogen-Free

## Content

Section	Subject	Page
1.	Absolute Maximum Ratings -----	3
2.	Thermal Resistance Ratings -----	3
3.	Electrical Characteristics -----	4
4.	Typical Operating Characteristics Diagram -----	5-7
5.	Measurement Schematic -----	8-9
6.	Marking Information -----	10
7.	Package of Dimension -----	11
8.	Appendix -----	12-13

## 1. Absolute Maximum Ratings ( $T_J=25^\circ\text{C}$ unless otherwise noted)

Parameter	Symbol	Values			Unit	
		Min.	Typ.	Max.		
Drain-Source Voltage	$V_{DS}$	-	-	650	V	
Gate-Source Voltage	$V_{GS}$	-	-	$\pm 30$	V	
Drain Current-Continuous <sup>Note 1</sup>	$I_D$	$T_C=25^\circ\text{C}$	-	-	20.4	A
		$T_C=100^\circ\text{C}$	-	-	12.9	A
Drain Current-Pulsed <sup>Note 2</sup>	$I_{DM}$	-	-	70	A	
Avalanche Current	$I_{AS}$	-	-	5.7	A	
Single Pulse Avalanche Energy <sup>Note 3</sup>	$E_{AS}$	-	-	129	mJ	
Maximum Power Dissipation	$P_D$	$T_C=25^\circ\text{C}$	-	-	189	W
		$T_C=100^\circ\text{C}$	-	-	75.7	W
		Derate Factor Above $T_C=25^\circ\text{C}$	-	-	1.51	W/ $^\circ\text{C}$
Body Diode $dv/dt$ <sup>Note 4</sup>	$dv/dt$	-	-	14.4	V/nS	
Max. Operating Junction Temperature	$T_J$	-	-	150	$^\circ\text{C}$	
Storage Temperature Range	$T_{STG}$	-55	-	150	$^\circ\text{C}$	

## 2. Thermal Resistance Ratings

Parameter	Symbol	Conditions	Min.	Typ.	Max.	Unit
Thermal resistance, Junction-Case <sup>Note 5</sup>	$R_{\theta JC}$	Steady State	-	-	0.66	$^\circ\text{C}/\text{W}$
Thermal resistance, Junction-Ambient <sup>Note 5</sup>	$R_{\theta JA}$	Steady State	-	-	41.26	$^\circ\text{C}/\text{W}$

### Notes:

- Limited by silicon chip capability and  $R_{\theta JC}$  junction-to-case thermal resistance.
- Must be ensure junction temperature does not exceed 150-degree C. (Pulse Width  $\leq 380\mu\text{s}$ , Duty  $\leq 2\%$ )
- Limited by  $T_{Jmax}$ , starting  $T_J=25^\circ\text{C}$ ,  $L=8\text{ mH}$ ,  $R_g=25\Omega$ ,  $I_{AS}=5.7\text{A}$ ,  $V_{GS}=10\text{V}$ .
- $V_{DD} = 0\sim 400\text{ V}$ ,  $I_{SD}=I_S \leq 10\text{ A}$  starting  $T_C = 25^\circ\text{C}$
- The value of thermal resistance is measured with the single device put on cooling plate under a still air environment temperature is 25 degree C based on JEDEC standard JESD51-14 and JESD51-2a. Thermal resistance obtained depends on the user's specific board design and given application.
- $C_{o(er)}$  is fixed capacitance that gives same stored energy as  $C_{OSS}$  while  $V_{DS}$  rising to 400V from 0V.
- $C_{o(tr)}$  is fixed capacitance that gives same charging time as  $C_{OSS}$  while  $V_{DS}$  rising to 400V from 0V.

### 3. Electrical Characteristics (T<sub>J</sub>=25°C unless otherwise noted)

STATIC CHARACTERISTICS						
Parameter	Symbol	Conditions	Min.	Typ.	Max.	Unit
Drain-Source Breakdown Voltage	BV <sub>DSS</sub>	V <sub>GS</sub> =0V, I <sub>DS</sub> =250μA	650	-	-	V
Zero Gate Voltage Drain Current	I <sub>DSS</sub>	V <sub>DS</sub> =650V, V <sub>GS</sub> =0V	-	-	1	μA
		V <sub>DS</sub> =650V, V <sub>GS</sub> =0V, T <sub>J</sub> =125°C	-	-	10	μA
Gate-Body Leakage Current	I <sub>GSS</sub>	V <sub>GS</sub> =±30V, V <sub>DS</sub> =0V	-	-	±100	nA

STATIC CHARACTERISTICS						
Parameter	Symbol	Conditions	Min.	Typ.	Max.	Unit
Gate Threshold Voltage	V <sub>GS(TH)</sub>	V <sub>DS</sub> =V <sub>GS</sub> , I <sub>DS</sub> =250μA	2.7	3.0	3.3	V
Drain-Source On-State Resistance	R <sub>DS(ON)</sub>	V <sub>GS</sub> =10V, I <sub>DS</sub> =12A	-	151	180	mΩ
Gate Resistance	R <sub>G</sub>	V <sub>GS</sub> =0V, V <sub>DS</sub> =0V, f=1MHz	-	4.6	-	Ω
Forward Transconductance	g <sub>fs</sub>	V <sub>DS</sub> =10V, I <sub>DS</sub> =12A	-	16.1	-	S

DYNAMIC CHARACTERISTICS						
Parameter	Symbol	Conditions	Min.	Typ.	Max.	Unit
Input Capacitance	C <sub>iss</sub>	V <sub>DD</sub> =650V, V <sub>DS</sub> =325V, V <sub>GS</sub> =0V, F=1MHz	-	1754	-	pF
Output Capacitance	C <sub>oss</sub>	V <sub>DD</sub> =650V, V <sub>DS</sub> =325V, V <sub>GS</sub> =0V, F=1MHz	-	20.7	-	pF
Reverse Transfer Capacitance	C <sub>rss</sub>	V <sub>DD</sub> =650V, V <sub>DS</sub> =325V, V <sub>GS</sub> =0V, F=1MHz	-	4.9	-	pF
Effective output capacitance-energy	C <sub>o(er)</sub>	V <sub>DD</sub> =400V, V <sub>G</sub> =10V, energy related <sup>Note 6</sup>	-	144	-	pF
Effective output capacitance-time	C <sub>o(tr)</sub>	V <sub>DD</sub> =400V, V <sub>G</sub> =10V, time related <sup>Note 7</sup>	-	598	-	pF
Turn-On Delay Time	T <sub>d(on)</sub>	V <sub>DS</sub> =400V, V <sub>GS</sub> =10V, I <sub>DS</sub> =10A, R <sub>GEN</sub> =10Ω	-	15.3	-	nS
Rise Time	t <sub>r</sub>	V <sub>DS</sub> =400V, V <sub>GS</sub> =10V, I <sub>DS</sub> =10A, R <sub>GEN</sub> =10Ω	-	22.2	-	nS
Turn-Off Delay Time	T <sub>d(off)</sub>	V <sub>DS</sub> =400V, V <sub>GS</sub> =10V, I <sub>DS</sub> =10A, R <sub>GEN</sub> =10Ω	-	83	-	nS
Fall Time	t <sub>f</sub>	V <sub>DS</sub> =400V, V <sub>GS</sub> =10V, I <sub>DS</sub> =10A, R <sub>GEN</sub> =10Ω	-	31.6	-	nS

GATE CHARGE CHARACTERISTICS						
Parameter	Symbol	Conditions	Min.	Typ.	Max.	Unit
Gate charge total	Q <sub>g 10V</sub>	V <sub>DD</sub> =400V, I <sub>D</sub> =10A, V <sub>GS</sub> =0 to 10V	-	40.2	-	nC
Gate to Source Gate Charge	Q <sub>gs</sub>	V <sub>DD</sub> =400V, I <sub>D</sub> =10A, V <sub>GS</sub> =0 to 10V	-	9.7	-	nC
Gate to Drain Charge	Q <sub>gd</sub>	V <sub>DD</sub> =400V, I <sub>D</sub> =10A, V <sub>GS</sub> =0 to 10V	-	13.3	-	nC
Gate plateau voltage	V <sub>plateau</sub>	V <sub>DD</sub> =400V, I <sub>D</sub> =10A, V <sub>GS</sub> =0 to 10V	-	5.0	-	V

BODY DIODE CHARACTERISTICS AND MAXIMUM RATINGS						
Parameter	Symbol	Conditions	Min.	Typ.	Max.	Unit
Diode continuous forward current	I <sub>S</sub>	T <sub>C</sub> =25°C	-	-	20.4	A
Diode pulsed forward current	I <sub>SM</sub>	T <sub>C</sub> =25°C	-	-	70	A
Diode forward Voltage	V <sub>SD</sub>	T <sub>C</sub> =25°C, V <sub>GS</sub> =0V, I <sub>S</sub> = 12A	-	0.84	1.0	V
Diode reverse Recovery Time	t <sub>rr</sub>	V <sub>DD</sub> =400V, I <sub>SD</sub> =10A, T <sub>C</sub> =25°C, di/dt=50A/μs	-	390	-	nS
Diode reverse Recovery Charge	Q <sub>rr</sub>	V <sub>DD</sub> =400V, I <sub>SD</sub> =10A, T <sub>C</sub> =25°C, di/dt=50A/μs	-	4137	-	nC
Diode peak reverse recovery current	I <sub>rm</sub>	V <sub>DD</sub> =400V, I <sub>SD</sub> =10A, T <sub>C</sub> =25°C, di/dt=50A/μs	-	22.3	-	A

## 4. Typical Operating Characteristics diagrams

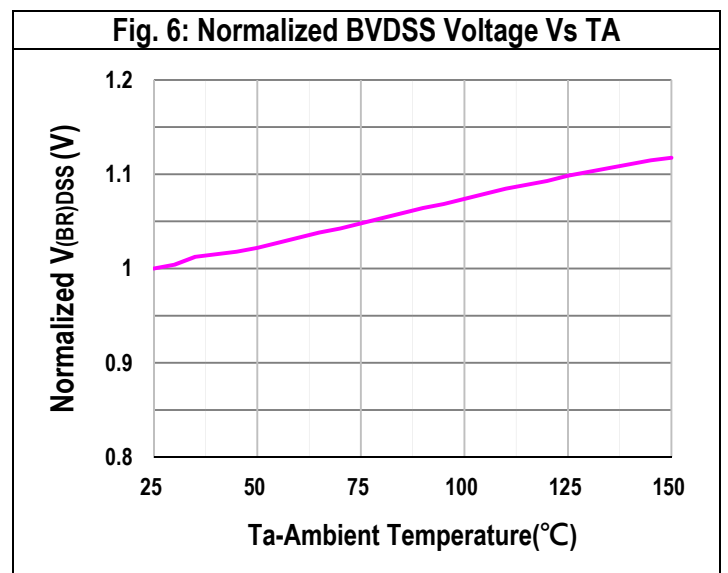
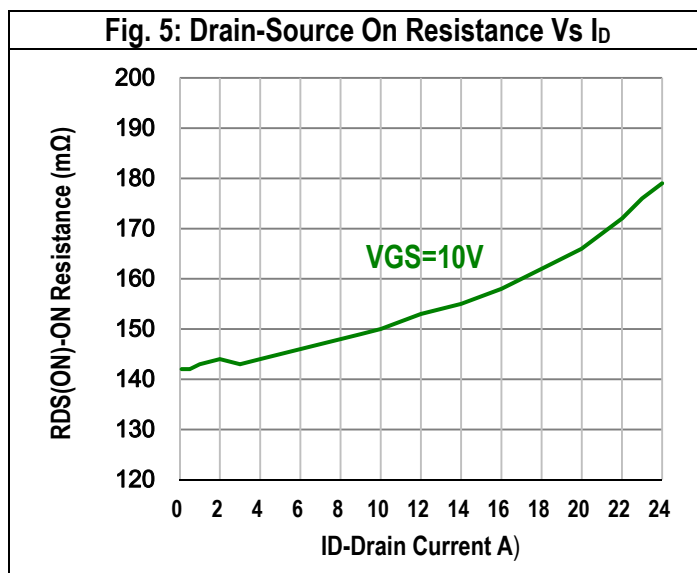
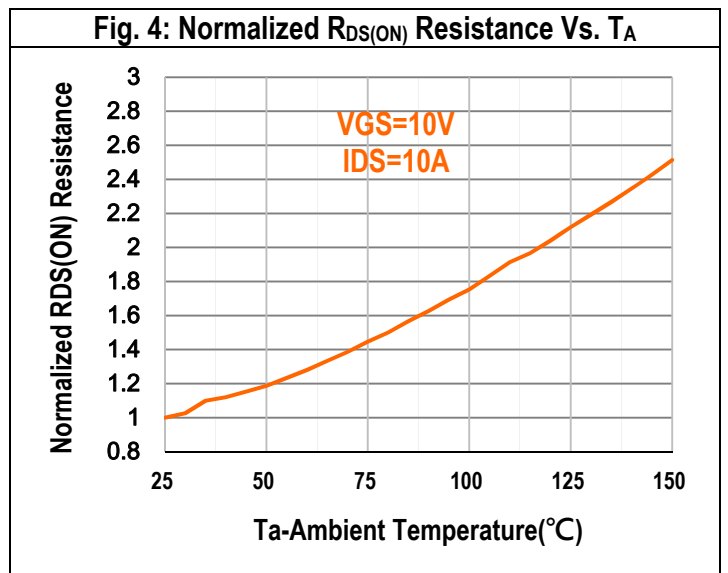
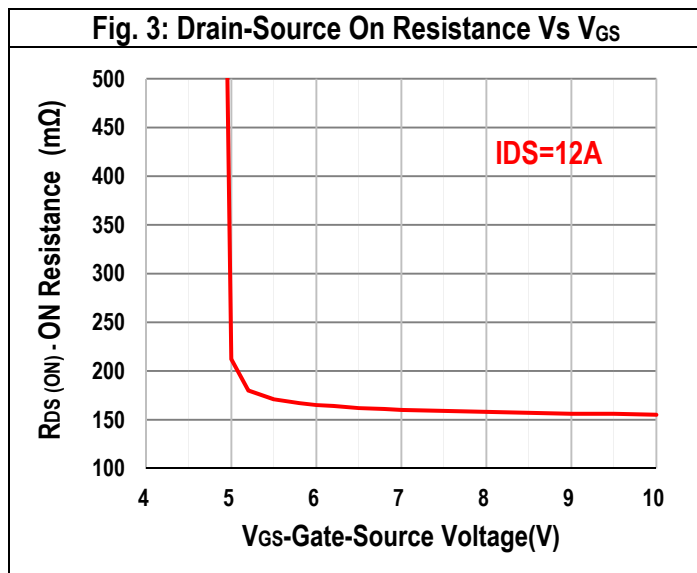
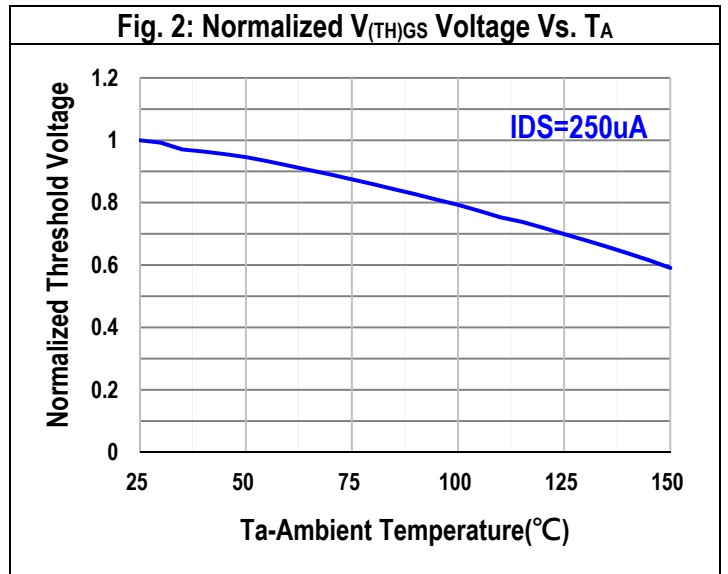
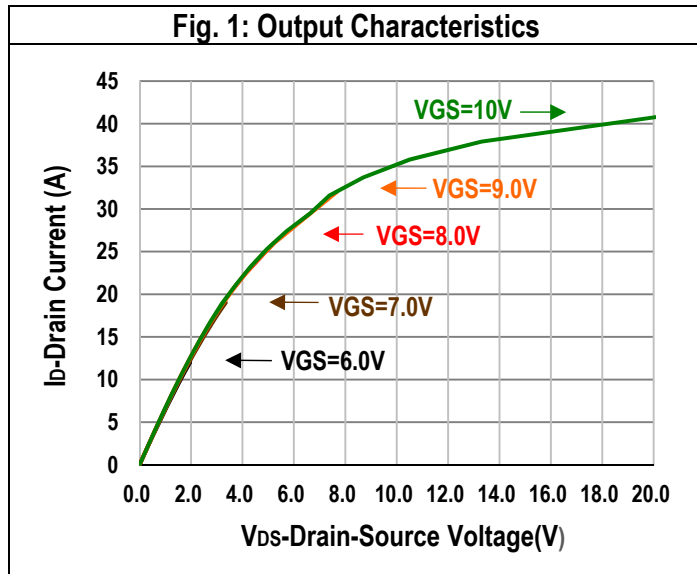

## 4. Typical Operating Characteristics diagrams

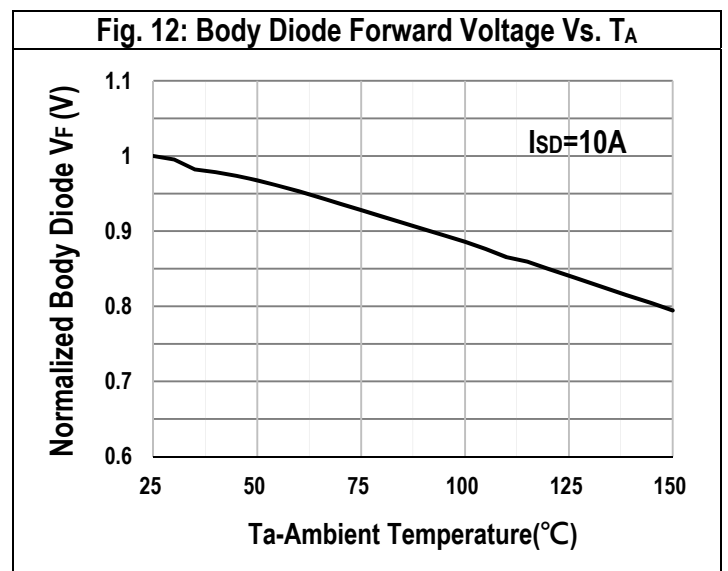
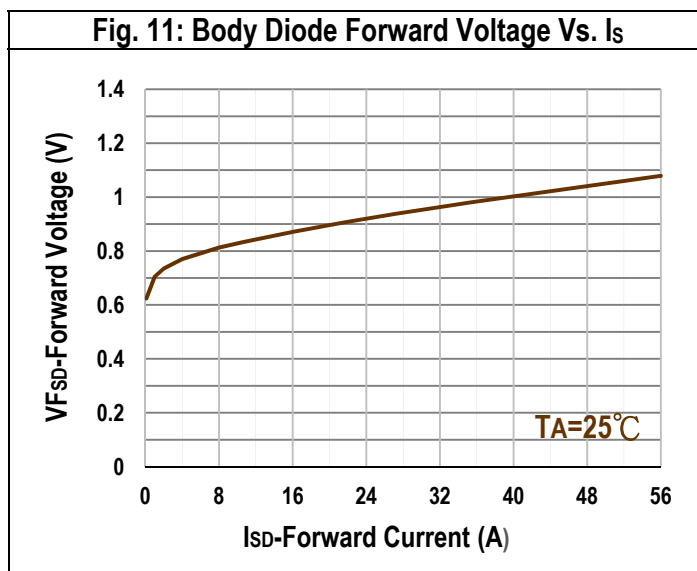
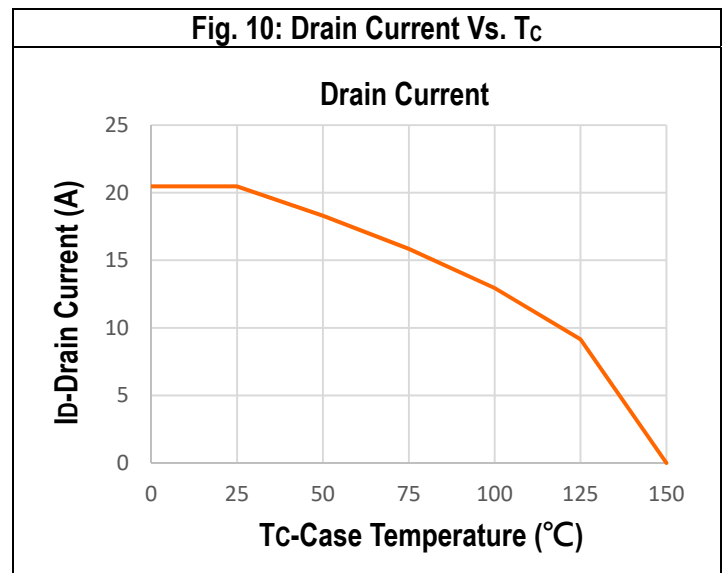
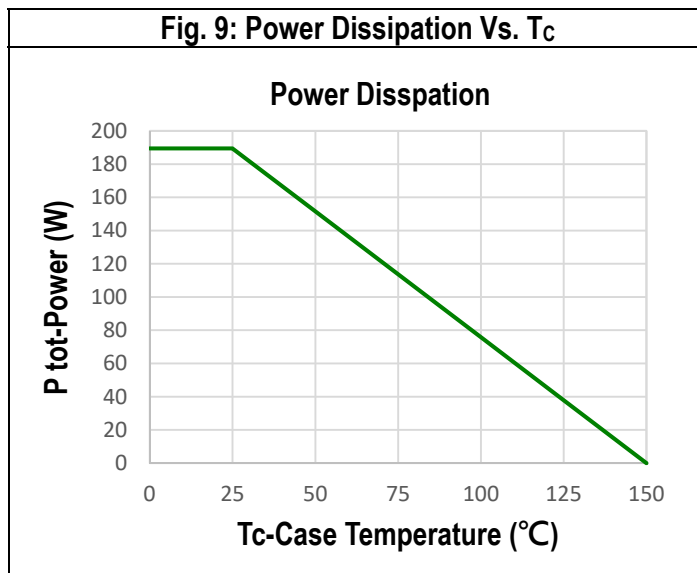
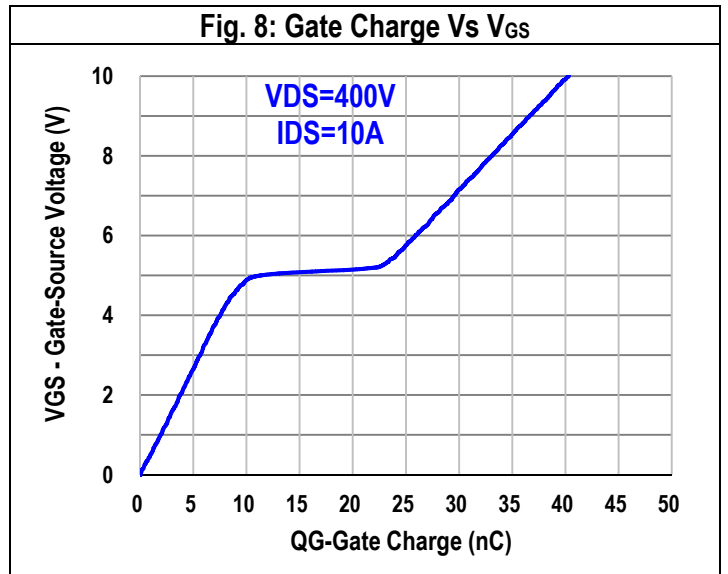
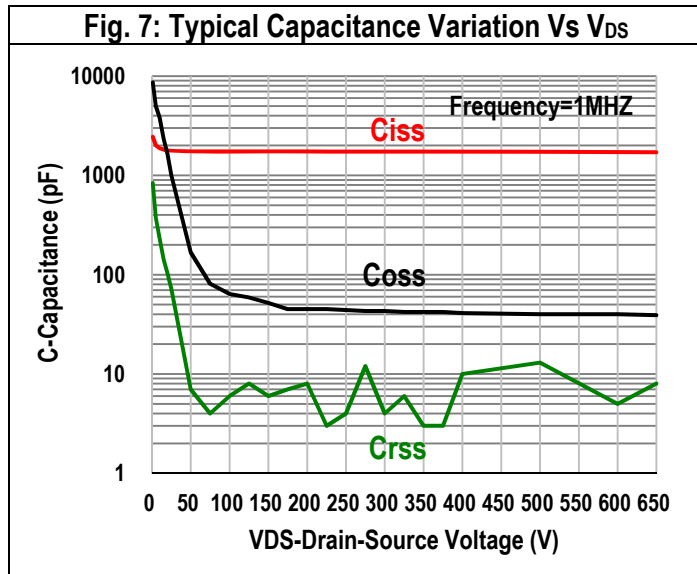

4. Typical Operating Characteristics diagrams

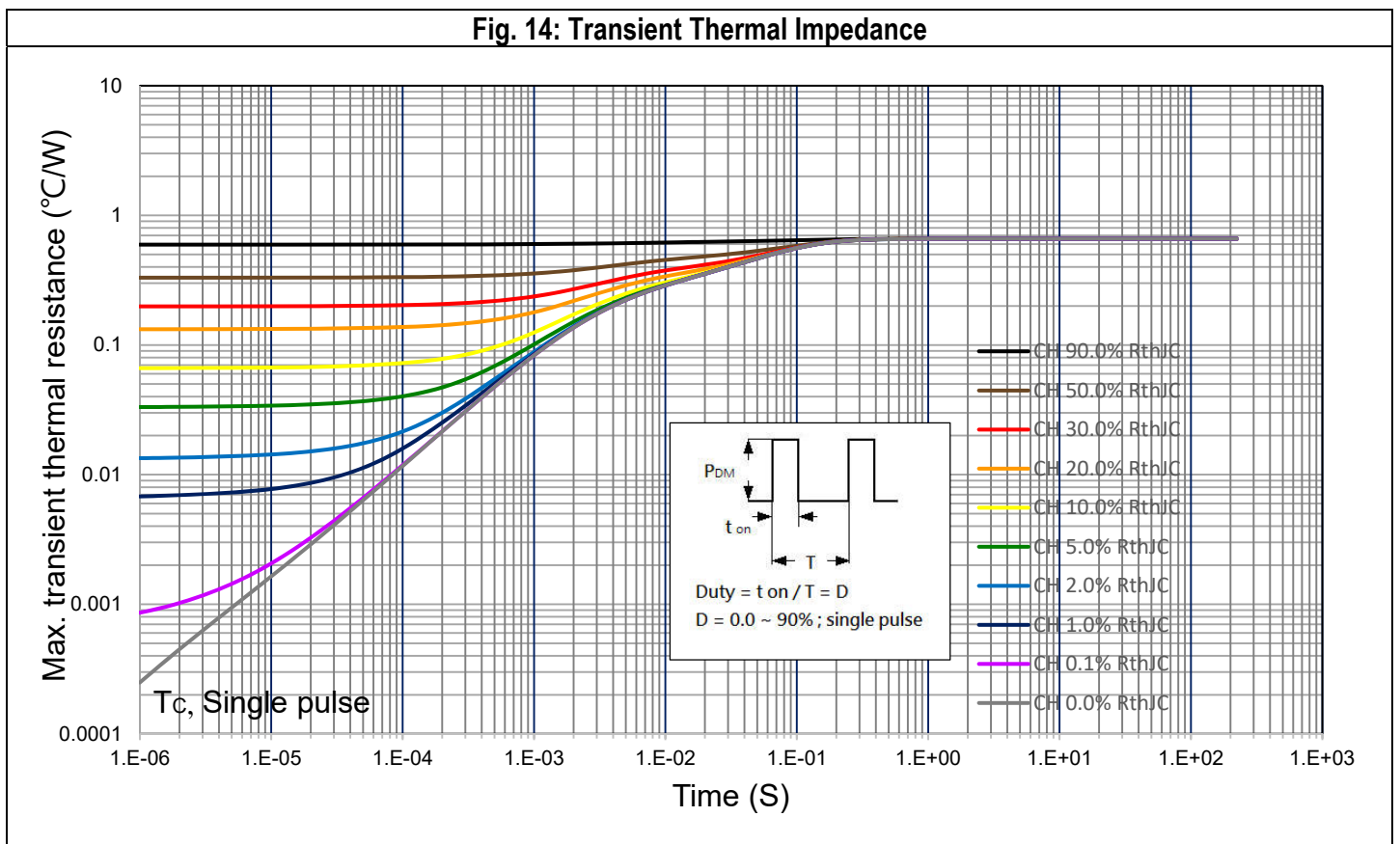
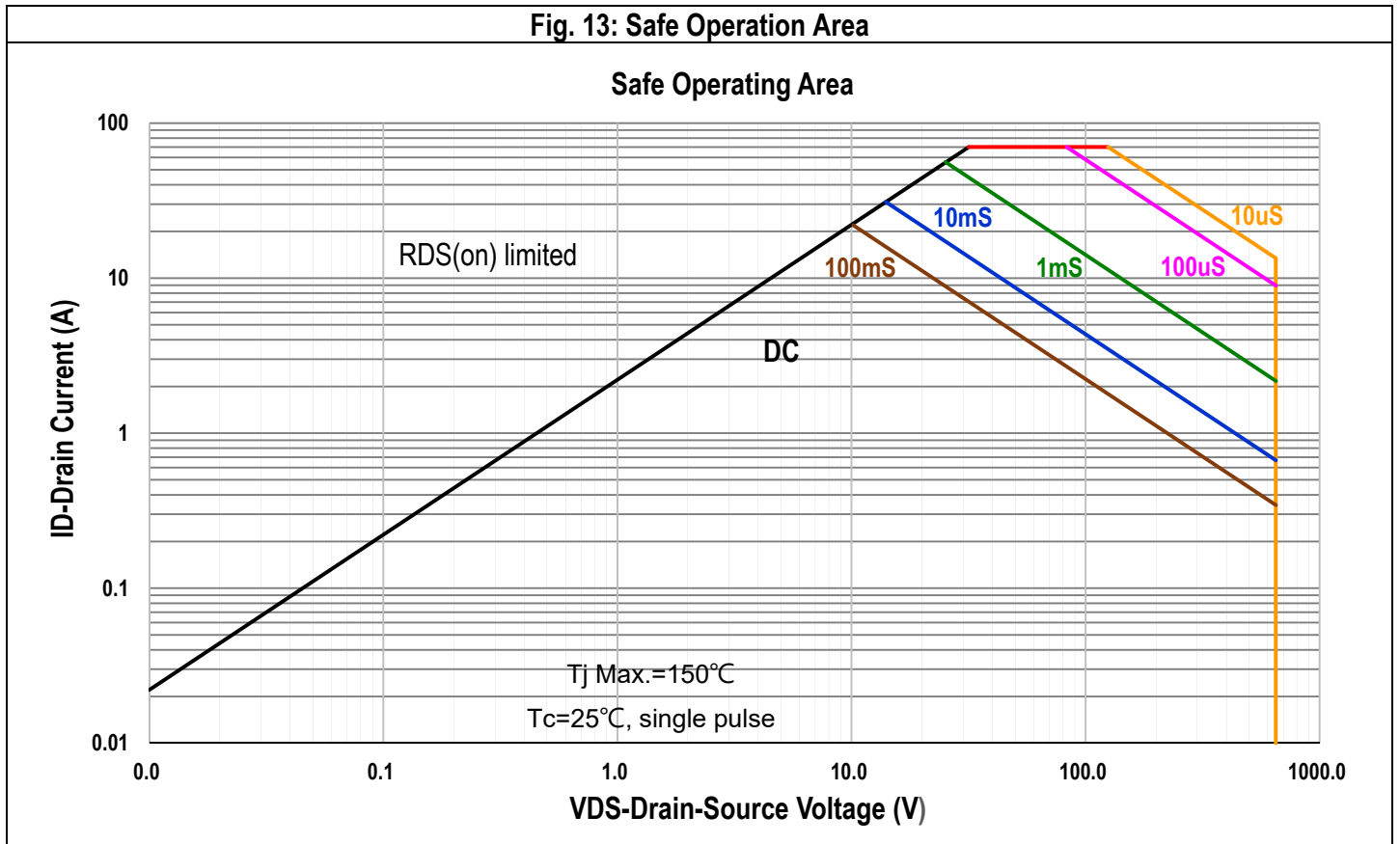

5. Measurement Schematic

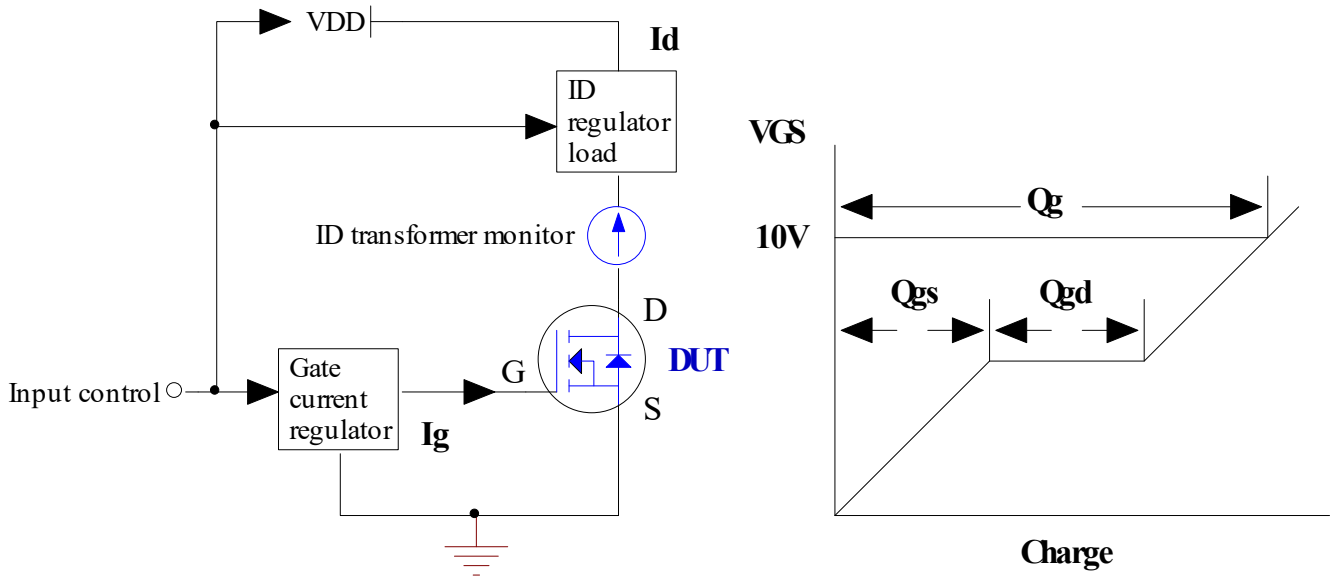

Diagram 5.1 Gate Charge Measurement Circuit and Waveforms

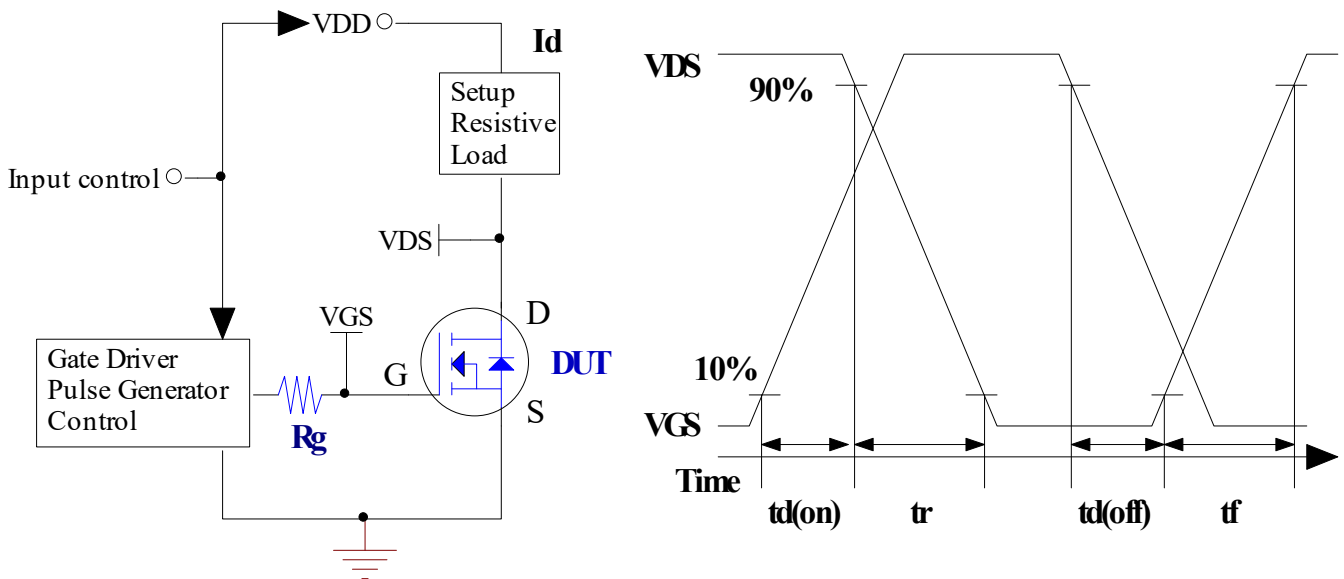

Diagram 5.2 Resistive Switching Measurement Circuit and Waveforms



5. Measurement Schematic

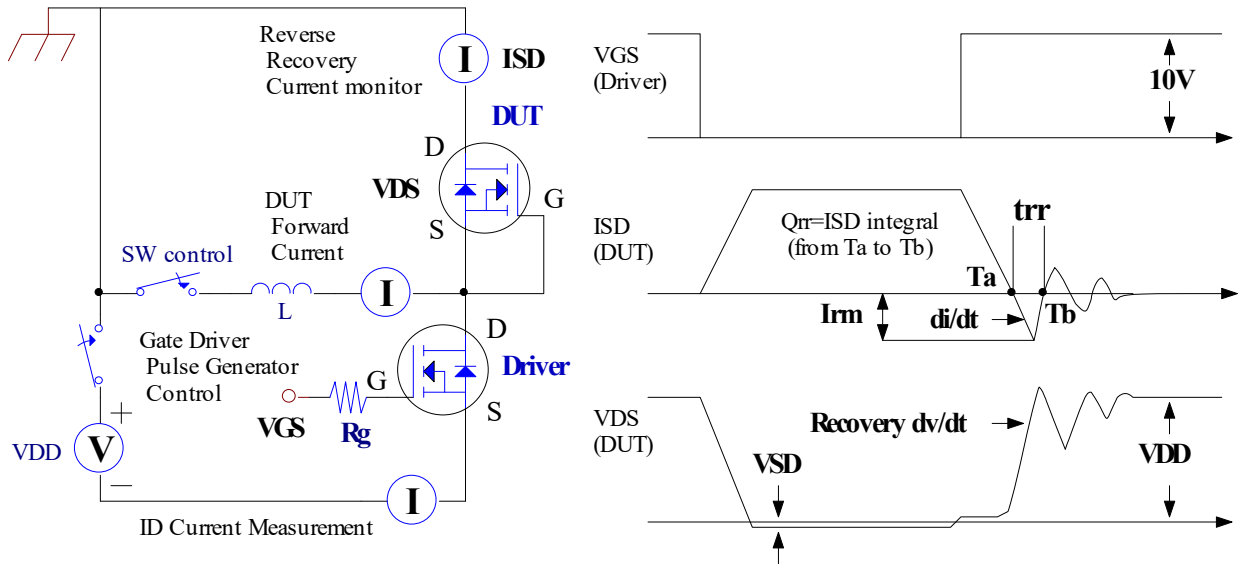

Diagram 5.3 Body Diode Recovery Characteristics Measurement Circuit and Waveforms

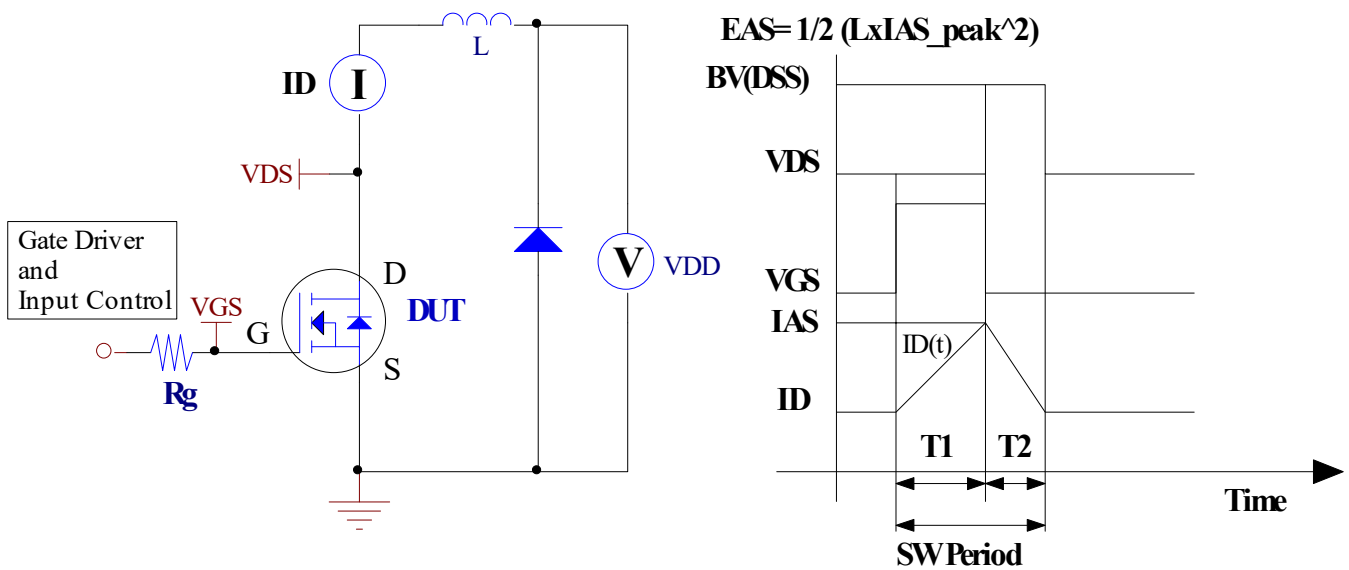
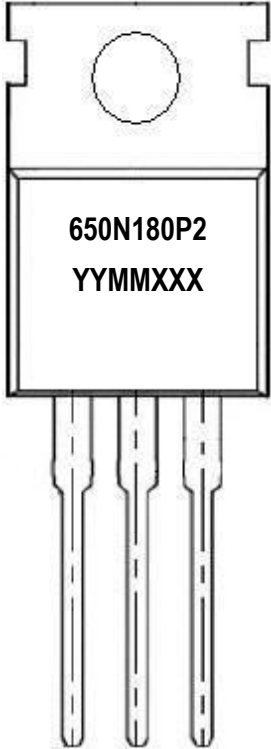

Diagram 5.4 Unclamped Inductive Switching Measurement Circuit and Waveforms

6. Marking Information

TO-220AB (P)	Marking Rule
<p>Laser Marking</p>  <p>The diagram shows a TO-220AB (P) MOSFET package. The top part of the package has a circular hole. Below the hole, there is a rectangular area containing the marking '650N180P2' on the first line and 'YYMMXXX' on the second line. Three leads extend from the bottom of the package.</p>	<p><u>Line 1</u> : Device 650N180P2</p> <p><u>Line 2</u> : Date Code YYMMXXX</p> <p>YY : Year Code MM : Month Code XXX : Serial Number</p>

## 7. Package of Dimension

Package type: TO-220AB

G-TYPE

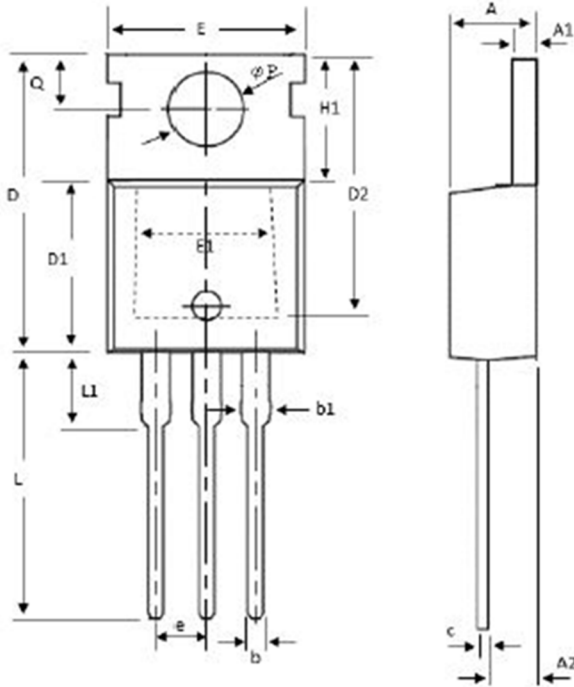

Symbol	Min	Nor	Max
A	4.20	4.45	4.70
A1	1.15	1.28	1.40
A2	2.20	2.45	2.70
b	0.70	0.83	0.95
b1	1.15	1.45	1.75
c	0.40	0.50	0.60
D1	8.80	9.10	9.40
D2	11.75	-	-
E	9.70	10.03	10.36
E1	6.86	-	-
e	2.54 BSC		
H1	6.25	6.55	6.85
L	12.75	13.38	14.00
L1	-	-	4.00
P	3.40	3.70	4.00
Q	2.60	2.80	3.00

P-TYPE  
H-TYPE

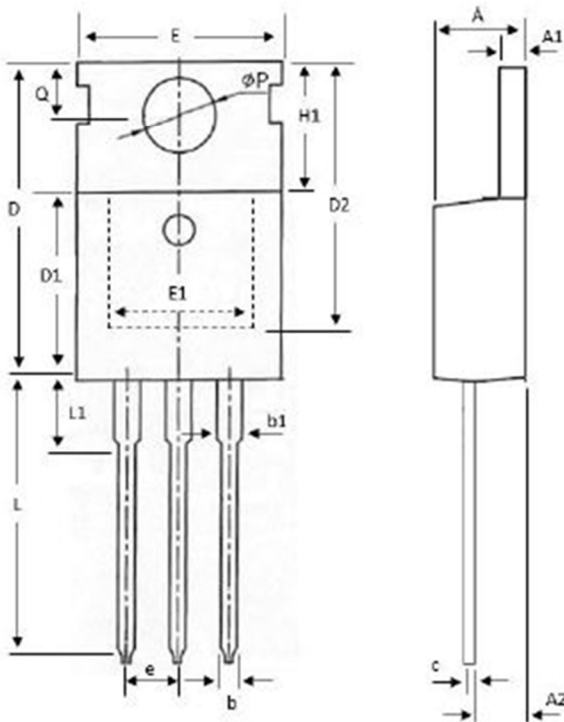

## 8. Appendix

### Appendix-A

#### Soldering Methods for Silicongear's Products (Just for SMD type of device)

1. Storage environment: Temperature=10°C to 35°C Humidity=65%±15%
2. Reflow soldering of surface-mount devices

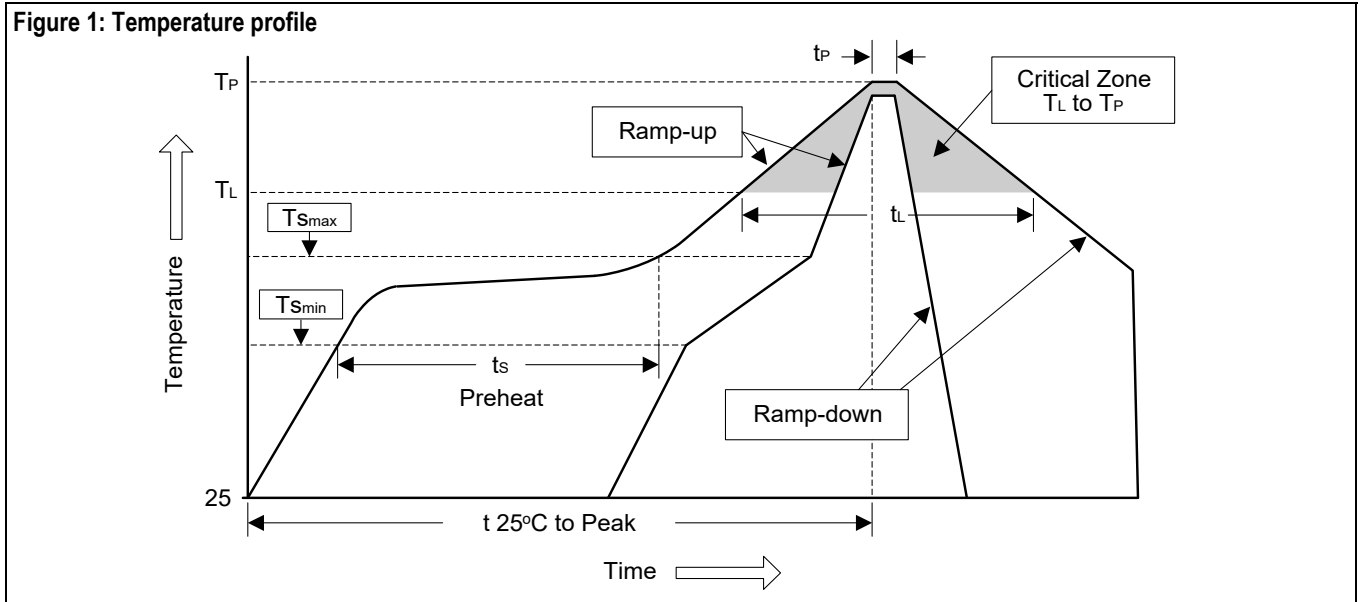

Profile Feature	Sn-Pb Eutectic Assembly	Pb-Free Assembly
Average ramp-up rate ( $T_L$ to $T_P$ )	<3°C/sec	<3°C/sec
Preheat		
- Temperature Min ( $T_{smin}$ )	100°C	150°C
- Temperature Max ( $T_{smax}$ )	150°C	200°C
- Time (min to max) ( $t_s$ )	60 to 120 sec	60 to 180 sec
$T_{smax}$ to $T_L$		
- Ramp-up Rate	<3°C/sec	<3°C/sec
Time maintained above:		
- Temperature ( $T_L$ )	183°C	217°C
- Time ( $t_L$ )	60 to 150 sec	60 to 150 sec
Peak Temperature ( $T_P$ )	240°C +0/-5°C	260°C +0/-5°C
Time within 5°C of actual Peak Temperature ( $t_P$ )	10 to 30 sec	20 to 40 sec
Ramp-down Rate	<6°C/sec	<6°C/sec
Time 25°C to Peak Temperature	<6 minutes	<8 minutes

#### 3. Flow (wave) soldering (solder dipping)

Products	Peak Temperature	Dipping Time
Pb devices.	245°C ±5°C	5sec ±1sec
Pb-Free devices.	260°C +0/-5°C	5sec ±1sec

**8. Appendix****Appendix-B****Important Notice****© Silicongear Corporation**

ALL PRODUCT, PRODUCT SPECIFICATIONS AND DATA ARE SUBJECT TO CHANGE WITHOUT NOTICE TO IMPROVE RELIABILITY, FUNCTION OR DESIGN OR OTHERWISE.

Silicongear cannot assume responsibility for use of any circuitry other than circuitry entirely embodied in an Silicongear product. No circuit patent licenses, copyrights, mask work rights, or other intellectual property rights are implied.

Silicongear Corporation, its affiliates, agents, and employees, and all persons acting on its or their behalf (collectively, "Silicongear"), disclaim any and all liability for any errors, inaccuracies or incompleteness contained in any datasheet or in any other disclosure relating to any product.

Silicongear makes no warranty, representation or guarantee regarding the suitability of the products for any particular purpose or the continuing production of any product. To the maximum extent permitted by applicable law, Silicongear disclaims (i) any and all liability arising out of the application or use of any product, (ii) any and all liability, including without limitation special, consequential or incidental damages, and (iii) any and all implied warranties, including warranties of fitness for particular purpose, non-infringement and merchantability.

Statements regarding the suitability of products for certain types of applications are based on Silicongear's knowledge of typical requirements that are often placed on Silicongear products in generic applications. Such statements are not binding statements about the suitability of products for a particular application. It is the customer's responsibility to validate that a particular product with the properties described in the product specification is suitable for use in a particular application. Parameters provided in datasheets and/or specifications may vary in different applications and performance may vary over time. All operating parameters, including typical parameters, must be validated for each customer application by the customer's technical experts. Product specifications do not expand or otherwise modify Silicongear's terms and conditions of purchase, including but not limited to the warranty expressed therein.

Except as expressly indicated in writing, Silicongear products are not designed for use in medical, life-saving, or life-sustaining applications or for any other application in which the failure of the Silicongear product could result in personal injury or death. Customers using or selling Silicongear products not expressly indicated for use in such applications do so at their own risk and agree to fully indemnify and hold Silicongear and its distributors harmless from and against any and all claims, liabilities, expenses and damages arising or resulting in connection with such use or sale, including attorneys fees, even if such claim alleges that Silicongear or its distributor was negligent regarding the design or manufacture of the part. Please contact authorized Silicongear personnel to obtain written terms and conditions regarding products designed for such applications.

No license, express or implied, by estoppel or otherwise, to any intellectual property rights is granted by this document or by any conduct of Silicongear. Product names and markings noted herein may be trademarks of their respective owners.

Silicongear and the Silicongear logo are trademarks of Silicongear Corporation. All other brand and product names appearing in this document are registered trademarks or trademarks of their respective holders.